

# User Guide

*Formula eSports Racing Wheel*

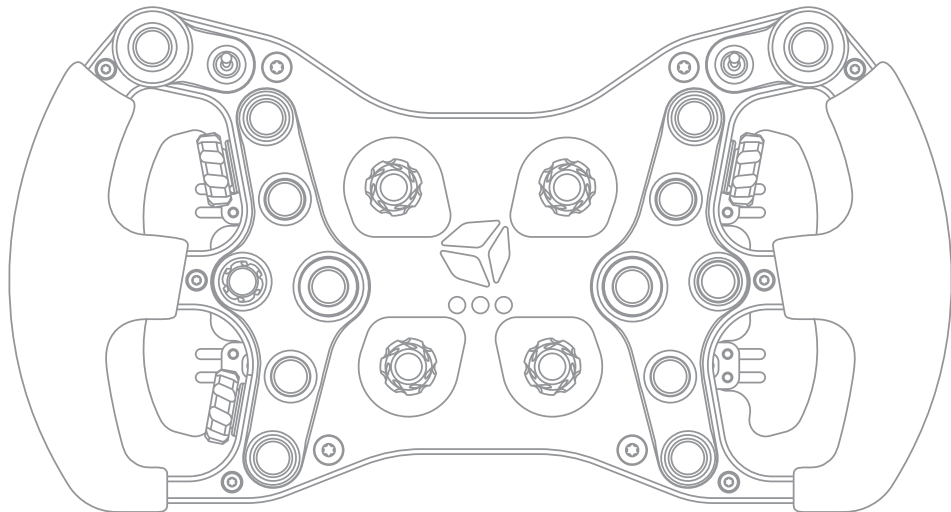

**FORME**®  
**CONTROLS**



*Due to continuous improvement, the actual product may differ from the manual.  
This manual is for reference only.*



# Safety notice

Please read the Manual carefully before you use the racing wheel.

Please do not open the racing wheel, otherwise the supplier will not afford warranty service.

This product does not have waterproof function, please keep it away from rain, moisture and other items containing liquid such as vape, cup and so forth.

This wheel is designed for simulation use only.

Disconnect the USB cable from both sides if you will not use this product for a long time.

Should you find any problems in your wheel, please contact us at [hello@cubecontrols.com](mailto:hello@cubecontrols.com), do not repair it by yourself.

# Interface introduction

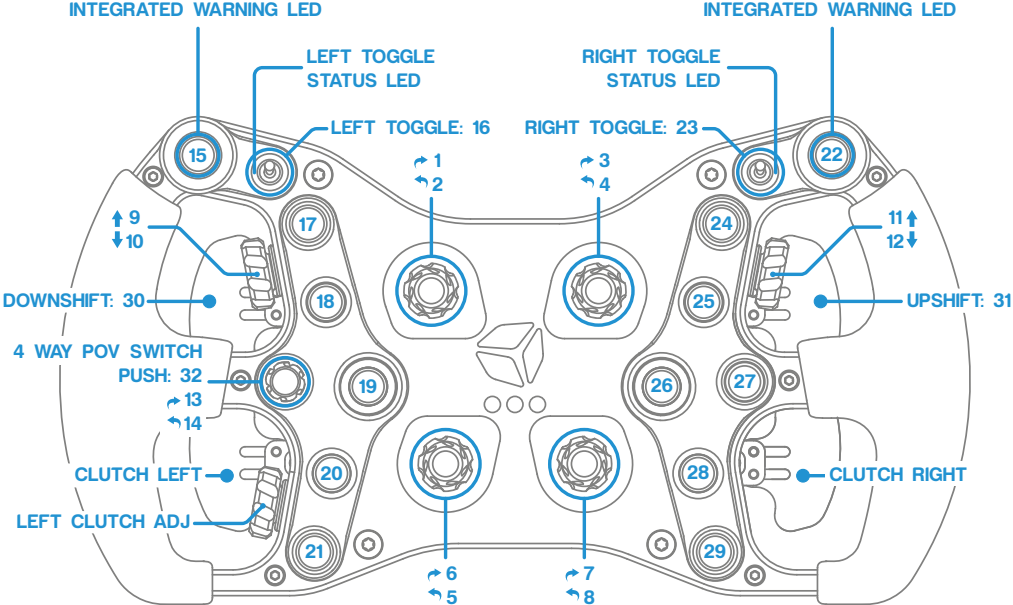

# Interface notes

15 - 22 integrated warning leds (as well as backlit buttons) are present only on **FORMULA-PRO** spec wheels.

To use the POV switch (up, down, left, right) you are supposed to just gently move the joystick knob into the desired direction. If you feel the tactile “click”, you are also pressing the center button (button 32).

## **Toggle switches and LEDs:**

Button 15 and 22 have integrated warning leds: once the button has been pressed the respective led will start flashing. Once it has been pressed again the flashing stops. Useful for warning options, pit limiter etc.

Toggles 16 and 23 works in a similar fashion: once the toggle has been activated the respective led will turn on, when the toggle has been flipped off it turns the led off. In the ON status the respective button is not seen as always pressed, it only activate the button for a few ms when flipped on or off.

Toggles are useful for on/off features like headlights, wipers, ABS/TC etc.

Make sure the warning and toggle leds are synced correctly: e.g. if you activate one option without being in the sim, it will work in reverse once you are into the simulator. To fix this just pause the sim, turn off the toggle and unpause the simulator.

## **Operating the launch control system:**

The maximum value of the left clutch paddle can be adjusted with the respective thumb knob. Therefore, if the clutch knob is set in the middle of its travel, when fully depressing the left clutch paddle, its value will go from the minimum to the value set by the clutch knob, which is middle in this example. The right paddle always works in a range from min to max travel, no matter how the clutch knob is set. This system allows the user to mimic the launch control system used in F1 cars until 2015, where it was possible to set the clutch bite point.

## **Finding the correct clutch knob setting:**

In a practice session, set the clutch knob at around 50% of its travel, fully depress both clutch paddles, engage first gear, reach the optimal engine RPM, release the right clutch paddle. As the car starts gaining speed, release the left clutch paddle and shift gears as normal. If you notice that the clutch starts slipping too much, you will need to decrease the left clutch paddle max value by turning downwards the clutch knob. If you notice that the engine drops quickly in RPM, then you will need to increase the clutch slippage by turning the clutch knob downwards.

This value is typically different for each car.

# USB connection

Connect the steering wheel to your PC by only using the provided cable.

Please note that the wheel connector it's keyed as the picture below, so it fits only one way.

Once the plug it's correctly seated into the body receptacle, secure it by turning the retaining ring as bottom right picture.

**IMPORTANT:** do not over-tighten the ring. Just screw it completely until it stops rotating, do not apply excessive force.

## Alignment key

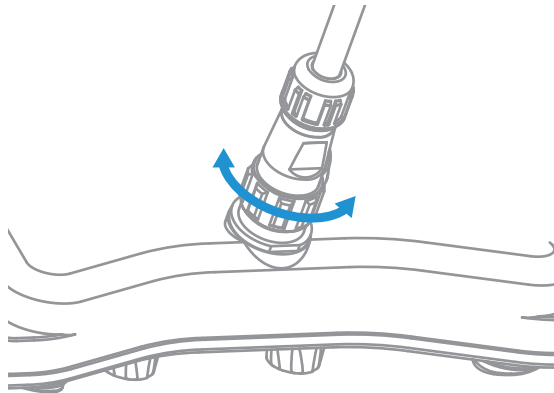
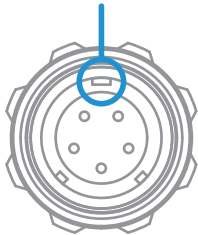

# Paddle shifters calibration

## Introduction:

Although all the racing wheels are already tested and should work correctly straight out the box, you might need to adjust the shifter sensor activation point for a correct use on your setup. **If the paddles are already set correctly, you may skip these steps.**

## Needed tools:

Torx T10 drive and a small philips screwdriver (both provided).

## Accessing the trimmers

Locate and remove the two Torx screws on the back of the wheel as highlighted in the next picture:

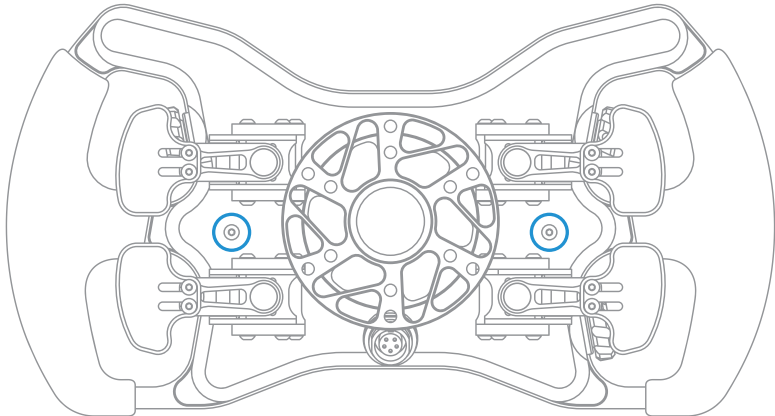



## Connect the steering wheel to your PC

Connect the racing wheel to your PC with the provided coiled USB cable, wait for your computer to recognize the device and in **Control Panel**, access the **Game Controllers** window.

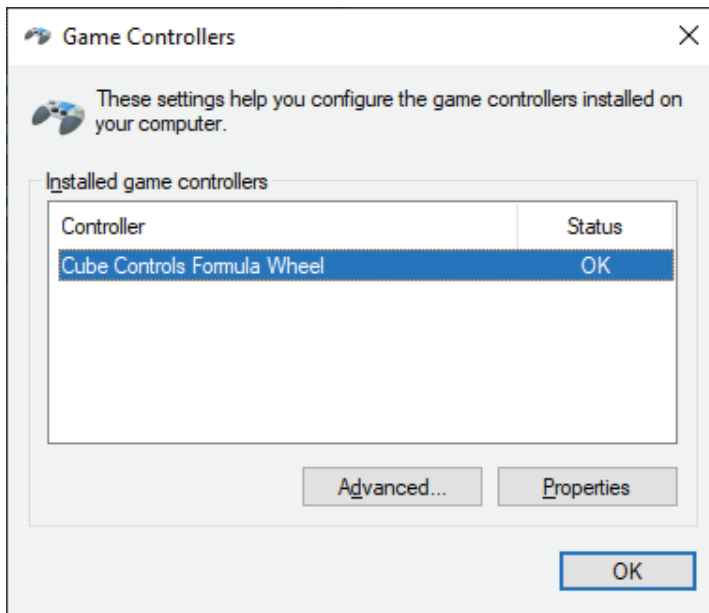

## Select your wheel

Select your Cube Controls Formula Wheel from the list and open the **properties panel**.

You should now see a window that displays all your steering wheels buttons:

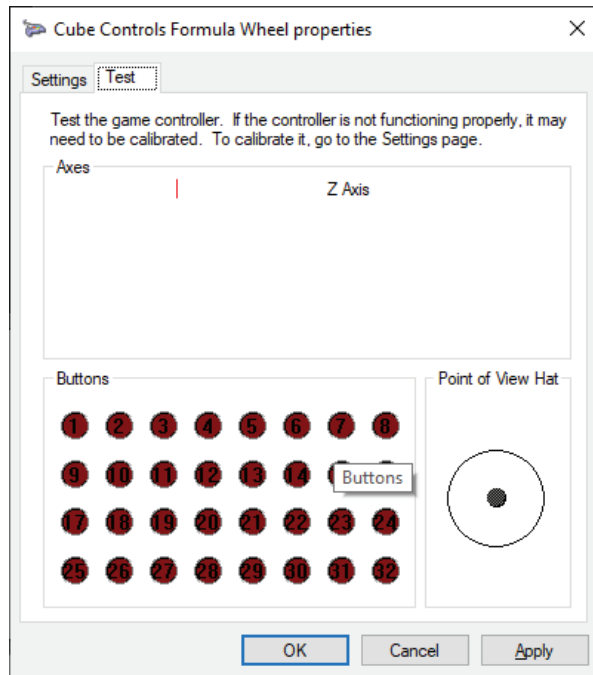

## Adjusting the trimmers

Carefully place a small philips screwdriver inside the screw hole leaved by the screw you removed in the previous step, and move it slightly until it engages the trimmer. It sits around 10mm below the surface of the main body.

There is one trimmer for each right (upshift) and left (downshift) paddles.

Press the paddle you are adjusting and keep it pressed, rotate the trimmer slowly clockwise or anticlockwise until the downshift button **(9)** or upshift button **(10)** are on.

**Please notice that the adjustment trimmer have end points on both ends, do not force the rotation if you reach them.**

Release the shifter, remove the screwdriver and check if the shifter is now working properly. If needed, please, do repeat this process for the other paddle.

Once you are done with the calibration, put back in place the Torx screws you removed at the beginning.

# Wheel installation

Our universal hub on the back of the wheel body allows the user to install various adapter, or even connect it directly to your FFB base.

Highlighted in blue the M5x0.8 metric holes.

In gray, 5,5mm through holes.

Both of them are available in 70mm or 50.8mm bolt pattern.

Through holes are rotated by 180°, so flipping your adapter to match the wheel hub may be needed.

Please refer to your adapter or motor manufacturer to ensure compatibility.

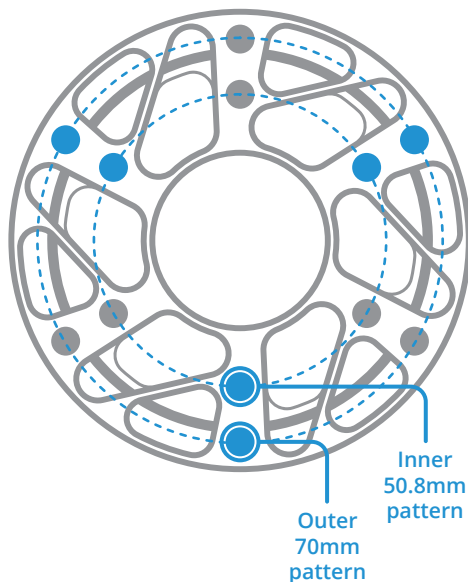

# Paddles adjustment

Clutch and shifter paddles can be easily adjusted to better suit your hand size and driving preferences.

**T10 drive needed.**

Length can be adjusted by slightly loosening the two screws highlighted in the right picture, and sliding forward/backwards the carbon paddle. ←

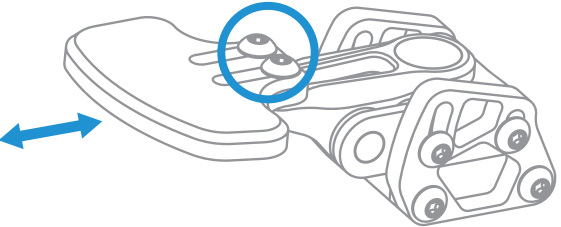

Reach can be adjusted by slightly loosening the two screws highlighted as the right picture and the two on the opposite side of the shifter as pointed by the small arrows, then rotating the lever body upwards/downwards. You may need to apply a bit of force.

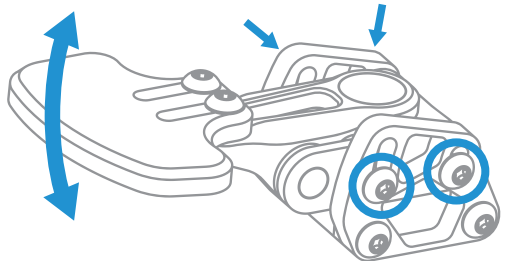

# Useful tips

Each wheel comes with a full sheet of stickers and a set of plastic tweezers useful to install them as your liking. **Before applying the sticker make sure the surface it's clean.**

Black and white long labels are designed to be placed over the dial setting name:



Try to install the USB coiled cable by wrapping it loosely on your FFB motor shaft/adaptor in such a way that it will not suffer any strain even when doing full opposite steering rotations.

On some systems the backlit buttons (available only on PRO spec wheels) will remain ON even when the PC it's turned off. You may need to change your PC power options and/or BIOS settings to avoid this.

Some simulators will require the analog clutch axis to be calibrated before use. Open the device properties as page 8-9, and click the settings tab. Click the "calibrate" button and follow the procedure on-screen.

Make sure your rig is grounded correctly. Main wheel body and hub are connected to the wheel own USB ground.

Each wheel comes with an auxiliary USB connector that comes out from the main hub. This will be used with our Cube Controls quick release kit.

# Shifters maintenance

If lubricant dries up you might experience the paddle shifter not coming back to its original position freely.

Once a year it's highly recommended to put a really small drop of lubricant (sewing machine oil or similar) on the points as the drawing on the right indicates, just where the lever body touches the base of the shifter when pressed down.

A small drop of lubricant on the contact point of the stainless steel pin as indicated by the arrow will help as well.

Do not use any spray products such as WD40 or similar.

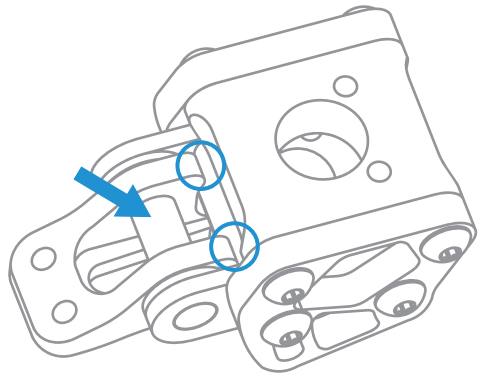

**Shifter unit bottom view**

# Notes



hello@cubecontrols.com

